



**Title:**

Are Ventilation Filters Degrading Indoor Air Quality in California Classrooms?

**Author:**

Fisk, Michael G. Apte and William J.

**Publication Date:**

09-23-2009

**Publication Info:**

Lawrence Berkeley National Laboratory

**Permalink:**

<http://www.escholarship.org/uc/item/8wf72612>

**Citation:**

Fisk, Michael G. Apte and William J.(2009). Are Ventilation Filters Degrading Indoor Air Quality in California Classrooms? . Lawrence Berkeley National Laboratory: Lawrence Berkeley National Laboratory. LBNL Paper LBNL-2177E. Retrieved from: <http://www.escholarship.org/uc/item/8wf72612>

**Abstract:**

<p>Heating, ventilating, and cooling classrooms in California consume substantial electrical energy. Indoor air quality (IAQ) in classrooms affects student health and performance. In addition to airborne pollutants that are emitted directly by indoor sources and those generated outdoors, secondary pollutants can be formed indoors by chemical reaction of ozone with other chemicals and materials. Filters are used in nearly all classroom heating, ventilation and air conditioning (HVAC) systems to maintain energy-efficient HVAC performance and improve indoor air quality; however, recent evidence indicates that ozone reactions with filters may, in fact, be a source of secondary pollutants. This project quantitatively evaluated ozone deposition in HVAC filters and byproduct formation, and provided a preliminary assessment of the extent to which filter systems are degrading indoor air quality. The preliminary information obtained will contribute to the design of subsequent research efforts and the identification of energy efficient solutions that improve indoor air quality in classrooms and the health and performance of students.</p>



# Are Ventilation Filters Degrading Indoor Air Quality in California Classrooms?

H Destailats, WJ Fisk, MG Apte

Environmental Energy Technologies Division  
Indoor Environment Department  
Lawrence Berkeley National Laboratory  
Berkeley, CA 94720

October 2008

The research reported here was supported by the California Energy Commission Public Interest Energy Research program award number CEC-500-2009-054, and the Assistant Secretary for Energy Efficiency and Renewable Energy, Office of the Building Technologies Program, U.S. Department of Energy under Contract No. DE-AC02-05CH11231.

# ARE VENTILATION FILTERS DEGRADING INDOOR AIR QUALITY IN CALIFORNIA CLASSROOMS?

*Prepared For:*

**California Energy Commission**  
Public Interest Energy Research Program

*Prepared By:*

Lawrence Berkeley National Laboratory



Arnold Schwarzenegger

PIER FINAL PROJECT REPORT

June 2009  
CEC-500-2009-054



***Prepared By:***

Lawrence Berkeley National Laboratory  
Hugo Destailats,  
Michael G. Apte and William J. Fisk  
Berkeley, CA 94720  
Commission Contract No. MEX-07-05  
Commission Work Authorization No. UC MR-069

***Prepared For:***

Public Interest Energy Research (PIER) Program  
**California Energy Commission**

Gina Barkalow

***Project Manager***

Beth Chambers

***Contract Manager***

Linda Spiegel

***Program Area Lead***

***Energy-Related Environmental Research***

Kenneth Koyama

***Office Manager***

***Energy Generation Research***

Martha Krebs, Ph.D.

***PIER Research Director***

Thom Kelly, Ph.D.

***Deputy Director***

***ENERGY RESEARCH & DEVELOPMENT DIVISION***

Melissa Jones

***Executive Director***



**DISCLAIMER**

This report was prepared as the result of work sponsored by the California Energy Commission. It does not necessarily represent the views of the Energy Commission, its employees or the State of California. The Energy Commission, the State of California, its employees, contractors and subcontractors make no warrant, express or implied, and assume no legal liability for the information in this report; nor does any party represent that the uses of this information will not infringe upon privately owned rights. This report has not been approved or disapproved by the California Energy Commission nor has the California Energy Commission passed upon the accuracy or adequacy of the information in this report.



## Acknowledgments

The authors acknowledge Dr. Lara A. Gundel (LBNL), Michael Spears (LBNL) and Jérémie Almosni (ILSA-Lyon), who participated in the planning and execution of the experimental work and data processing; Aaron Glimme (Berkeley High School) for facilitation and coordination of filter deployment and retrieval; and Ed Vine (LBNL and California Institute of Energy and Environment) for his guidance and support.

Please cite this report as follows:

Destailats, Hugo, Michael G. Apte, and William J. Fisk, 2008. *Are Ventilation Filters Degrading Indoor Air Quality in California Classrooms?* California Energy Commission, PIER Energy-Related Environmental Research Program. CEC-500-2009-054.



## Preface

The California Energy Commission's Public Interest Energy Research (PIER) Program supports public interest energy research and development that will help improve the quality of life in California by bringing environmentally safe, affordable, and reliable energy services and products to the marketplace.

The PIER Program conducts public interest research, development, and demonstration (RD&D) projects to benefit California.

The PIER Program strives to conduct the most promising public interest energy research by partnering with RD&D entities, including individuals, businesses, utilities, and public or private research institutions.

PIER funding efforts are focused on the following RD&D program areas:

- Buildings End-Use Energy Efficiency
- Energy Innovations Small Grants
- Energy-Related Environmental Research
- Energy Systems Integration
- Environmentally Preferred Advanced Generation
- Industrial/Agricultural/Water End-Use Energy Efficiency
- Renewable Energy Technologies
- Transportation

*Are Ventilation Filters Degrading Indoor Air Quality in California Classrooms?* is the report for the Are Ventilation Filters Degrading Indoor Air Quality in California Classrooms? project (Contract Number E598-01, Work Authorization Number MEX-07-05) conducted by Lawrence Berkeley National Laboratory. The information from this project contributes to PIER's Energy-Related Environmental Research Program.

For more information about the PIER Program, please visit the Energy Commission's website at [www.energy.ca.gov/pier](http://www.energy.ca.gov/pier) or contact the Energy Commission at 916-654-5164.



# Table of Contents

Acknowledgments .....	i
Preface.....	iii
Table of Contents .....	v
List of Figures .....	vii
List of Tables.....	ix
Executive Summary .....	1
1.0 Introduction .....	3
2.0 Methods.....	5
2.1 Procurement and storage of filters .....	5
2.2 Experimental setup.....	5
2.3 Sample collection .....	6
3.0 Results.....	7
3.1 Ozone loss in HVAC filters .....	7
3.2 Identification and quantification of oxidation byproducts.....	10
3.3. Estimated impact in school air quality .....	13
4.0 Conclusions.....	17
5.0 References .....	19
List of Acronyms .....	21



## List of Figures

Figure 1: Flow tube experimental setus .....	6
Figure 2: Ozone breakthrough curves corresponding to unused cotton/polyester filters under humid (red) and dry (blue) air. ....	7
Figure 3: Ozone breakthrough curves corresponding to cotton/polyester filters used in Building H (classrooms) tested in the laboratory under humid (red) and dry (blue) air conditions.....	8
Figure 4: Average outlet formaldehyde concentrations for unused cotton/polyester blend media, and for the same filter material used in Bldg H and in the Gym building. The error bar indicates one standard deviation of five blank determinations. Chronic Reference Exposure Level (CREL) for formaldehyde is $3 \mu\text{g m}^{-3}$ .....	11
Figure 5: Average outlet acetaldehyde concentrations for unused cotton/polyester blend media, and for the same filter material used in Bldg H and in the Gym building. The error bar indicates one standard deviation of five blank determinations. Chronic Reference Exposure Level (CREL) for acetaldehyde is $9 \mu\text{g m}^{-3}$ . ....	12



## List of Tables

Table 1: Experimental conditions and results for unused filters.....	9
Table 2: Experimental conditions and results for used filters .....	9
Table 3: Indoor/outdoor (I/O) ratios reported for school buildings and their estimated ozone loss for high outdoor ozone conditions .....	13
Table 4: Estimation of yields of formaldehyde( $Y_F$ ) and acetaldehyde ( $Y_A$ ) corresponding to a cotton/polyester blend filter. ....	14



## Abstract

Heating, ventilating, and cooling classrooms in California consume substantial electrical energy. Indoor air quality (IAQ) in classrooms affects student health and performance. In addition to airborne pollutants that are emitted directly by indoor sources and those generated outdoors, secondary pollutants can be formed indoors by chemical reaction of ozone with other chemicals and materials. Filters are used in nearly all classroom heating, ventilation and air-conditioning (HVAC) systems to maintain energy-efficient HVAC performance and improve indoor air quality; however, recent evidence indicates that ozone reactions with filters may, in fact, be a source of secondary pollutants. This project quantitatively evaluated ozone deposition in HVAC filters and byproduct formation, and provided a preliminary assessment of the extent to which filter systems are degrading indoor air quality. The preliminary information obtained will contribute to the design of subsequent research efforts and the identification of energy efficient solutions that improve indoor air quality in classrooms and the health and performance of students.

**Keywords:** Ventilation, filters, ozone, HVAC, VOC, secondary pollutants, formaldehyde, acetaldehyde



# Executive Summary

## Introduction

Recent studies have found that used particle-loaded filters from offices degrade perceived air quality, react with ozone, and are associated with reduced work performance. This issue is of special concern for California classrooms, which operate under high exchange rates, due to high occupancy, bringing more ozone to the filters than in buildings operating at lower air exchange rates. This problem is particularly critical in areas of the state with elevated outdoor ozone levels. Ozone deposition and reaction on the surface of HVAC filters has the potential to generate secondary pollutants of concern. This project intended to assess the potential impact of ozone surface chemistry in HVAC filters in classrooms by understanding physical and chemical phenomena leading to the degradation of indoor air quality.

## Purpose

- To obtain a better understanding of the potential for indoor air quality degradation in California classrooms due to ozone reactions in ventilation system filters.

## Project Objectives

- To obtain preliminary information on the extent of ozone loss in filters, and the formation of secondary byproducts.
- To define future related research needs.

## Project Outcomes

The growing literature on ozone reactivity over HVAC filter media was reviewed, and main results are reported in the Introduction (Section 1.0).

Filters from school buildings were analyzed to evaluate quantitatively their ozone deposition capacity and byproduct formation. Unused filters were also analyzed to evaluate the effect of filter matrix vs. the effect of dust and particles collected on the filter surface. The results of this study indicate that reactions of ozone with filters can produce formaldehyde and acetaldehyde; however, the production rates are small and will generally not increase indoor concentrations of these aldehydes significantly relative to their typical indoor concentrations.

## Conclusions

This exploratory result provided quantitative information on ozone loss and byproduct formation of filters used in school buildings, as well as of unused filters of the same type. The main observations are:

- Ozone losses in filters taken from classrooms are significant in magnitude to partially explain prior findings that indoor ozone concentrations are often 30 percent to 70 percent lower than outdoor ozone concentrations.

- The reactions of ozone on particle-loaded filters from classrooms are a source of formaldehyde and acetaldehyde. The expected increases in indoor air concentrations of formaldehyde and acetaldehyde from this source are small relative to typical concentrations of these compounds in classrooms but significant relative to the California Energy Action Plan chronic reference exposure level of 2.5 ppbv (part-per-billion in volume) for formaldehyde.
- More research is needed before conclusions can be drawn about the health significance of ozone's reactions with the filters used in classrooms. For example, more information is required on the relative impact of ozone reactions with filters with respect to other existing formaldehyde sources. In the absence of other strong sources, more information is needed on long-term, low-level exposure to volatile aldehydes. Similar tests should be performed with filters of different types and locations and with a broader spectrum of analysis for production of other types of pollutants.

### **Recommendations**

More fundamental information is needed to evaluate the relative impact of ozone reactions with HVAC filters as compared with other indoor sources. In addition, more studies should evaluate the health effects of long-term, low-levels of volatile aldehydes formed in this reaction.

### **Benefits to California**

Classroom HVAC systems are direct and indirect electricity-consuming devices. Outdoor ozone and atmospheric particles are partly generated as a consequence of electricity production. Potential solutions to indoor air quality deterioration due to ozone reactions in HVAC filters could benefit ratepayers via improved health and school performance. Also, potential solutions, such as more frequent filter replacement, could save electricity.

## 1.0 Introduction

Heating, ventilation and air conditioning (HVAC) systems are commonly found in offices, health care facilities, schools, and other indoor workplaces in the U.S. Particulate matter and sorbed chemicals (i.e., semivolatile organic compounds that partition between the gas phase and indoor surfaces) collected on the surface of HVAC filters are materials susceptible to ozone attack. These filters are the first major surface at which outdoor ozone can react during its transit into the indoor environment. Ozone concentration at the HVAC intake is close to its outdoor value, i.e., considerably higher than levels downstream in the workspace (indoor ozone concentration). While HVAC systems are operating, particles are being deposited on their filters continually, providing fresh supplies of reactive material with a very large effective surface area. This potential pollutant source is of special concern for California classrooms because:

- Classrooms have high air exchange rates, due to high occupancy, which bring more ozone to the filters than low air exchange rates.
- Classrooms have high particle concentrations, thus, filters will be quickly loaded with particles.
- Limited HVAC maintenance, including filter replacement, is anecdotally very common in schools, suggesting that filters may often be highly loaded with particles.
- Outdoor ozone is elevated in many areas of California.

In recent studies of 100 office buildings (Apte et al, 2008; Buchanan et al., 2008), a significant correlation was observed between indoor formaldehyde and outdoor ozone levels. Prior research has documented loss of ozone as air flows through filters (Hytinen et al, 2003), and older filters, heavily laden with particles, have been associated with health symptoms, degraded perceived air quality and reduced work performance (Pasanen et al., 1994; Clausen et al., 2002; Clausen, 2004). The combination of these factors may constitute a significant source of indoor secondary pollutants and aerosol particles, considering that a recent report indicated that up to 11% of ozone removed by HVAC filters generated formaldehyde (Hytinen et al., 2006). A European study performed in a primary school revealed that, when ventilation filters were removed from the supply air duct, perceived air quality improved significantly (Mysen et al., 2006). In a literature survey, Mendell and Heath (2005) found evidence suggesting that poor indoor air quality in schools is common, and adversely influences the performance and attendance of students, primarily due to health effects of indoor pollutants.

Formaldehyde is an ubiquitous indoor pollutant: mixing ratios measured in 100 office buildings (USEPA, 2003; Girman et al., 1995) were in the range 0 – 50 ppbv, with a mean of 10.9 parts per billion (ppbv), a median of 9.0 ppbv and a standard deviation of 1.2 ppbv. These results are consistent with formaldehyde concentrations measured in 190 North American residences, with a median of 17 ppbv and upper (90<sup>th</sup>) percentile of 37 ppbv (Hodgson and Levin, 2003). Formaldehyde is a pollutant of concern in indoor environments, and particularly in classrooms. The World Health Organization has re-classified it as a known human carcinogen (Cogliano et al., 2005). In a study performed in relocatable classrooms in California, Hodgson et al. (2004)

observed that formaldehyde was the only volatile organic compound (VOC) consistently exceeding its chronic reference exposure levels (CREL, the concentration at or below which no long-term health effects are expected, of 3  $\mu\text{g}/\text{m}^3$ ). The same indoor chemical reactions that generate formaldehyde also generate several other toxic or irritant secondary pollutants, and a large number of ultrafine aerosol particles (Destailats et al., 2006).

In this exploratory study, ozone deposition in HVAC filters and reactions involving filter surface materials and surface-bound pollutants were investigated. Such reactions between a reactive air pollutant and surface materials at the gas-surface interface have been recently recognized as key processes in the indoor environment. Weschler (2004) identified heterogeneous chemistry as one of the most critical aspects of indoor air quality that deserve further study, and one of the potentially higher contributors to indoor pollution. Other authors have showed that loaded HVAC filters contributed to the degradation of perceived air quality, Sick Building Syndrome (SBS) symptoms and performance of office work (Pasanen et al., 1994; Clausen et al., 2002; Clausen, 2004). Hyttinen et al. (2003) observed the reaction of ozone with particle-laden filters used in office buildings and found ozone removal was ~5 % during winter tests and ~11 % in the summer, a period with higher relative humidity. Extent of ozone removal was affected also by the nature of the particles collected on filters, with up to 25-30% continuous abatement by sooty filters (Hyttinen et al., 2006). Formaldehyde concentrations downstream of the filters were higher than upstream values. In subsequent studies, the same authors reported the formation of formic acid along with formaldehyde (Hyttinen et al., 2005). Up to 11% of the ozone removed participated in the production of formaldehyde, suggesting that this reaction may be a significant contributor to indoor formaldehyde levels (Hyttinen et al., 2006). The creation/growth of ultrafine particles during similar experiments was attributed to desorption of low volatility oxidation products generated in ozone reactions with filter material (Bekö et al., 2005), and to the reaction of ozone with sorbed reactive VOCs such as terpenoids, unsaturated biogenic hydrocarbons derived from isoprene (Fadeyi et al., 2006). Bekö et al. (2003) evaluated the ozone removal efficiency of particle-laden HVAC filters, observing that an initial efficiency of 55 % dropped to ~ 5 % within an hour. However, upon successive exposures to ozone after a 24-48 hr period in contact with clean air, the removal efficiency returned to essentially the same initial value, suggesting that slow processes (diffusion, chemical reactions) regenerated the ozone uptake capacity of the particles captured by the filter.

## 2.0 Methods

### 2.1. Procurement and Storage of Filters

A total of 15 used filters were obtained from high school classrooms, administrative building and gymnasium buildings at one school in the San Francisco Bay Area. All filters were of the same type, a cotton/polyester blend of MERV 7 ASHRAE efficiency, and had been in operation from October 2007 to March 2008. Filters with MERV efficiency rating of 7 are able to retain between 50% and 70% of particles in the size range 3-10  $\mu\text{m}$ . Filters were obtained from four different buildings: Building D (administrative offices), Buildings G and H (mostly classrooms) and the Gymnasium. Dust and aerosol particles collected on the filters were of mixed outdoor and indoor origin. In addition to these filters, experiments were performed with unused filter samples of the same type (cotton/polyester blend) as well as with unused fiberglass filters. In all cases, filters were wrapped with aluminum foil and stored at room temperature under 40-60% relative humidity (RH) before exposure to ozone and analysis. Samples exposed to ozone were stored in a freezer. The mass of the exposed filters was determined with an analytical balance.

### 2.2. Experimental Setup

The experimental setup used in this study is shown in Figure 1. A clean airflow was split into two similar streams, one of which ran through the filter while the other was used as a reference. The ozone level was controlled with an ozone generator (UVP Inc., Upland, California) upstream of the filters, and the humidity was adjusted by circulating part of the incoming airflow through a water bubbler (humidifier). The ozone level was measured at 5-min intervals, alternatively at the filter and the reference flow, using a photometric monitor (Teledyne-API 400). A multiplexing valve was used to switch from the filter to the reference. Gas phase and aerosol samples were collected through ports located downstream of the exposed filters. The experimental setup was operated under room temperature, in the range 21-24  $^{\circ}\text{C}$  (70-75 F), controlled by the laboratory thermostat. System temperature and RH, as well as ozone concentrations, were recorded continuously in a data logging system (Automated Performance Testing, APT, The Energy Conservatory, Minneapolis, MN). Stainless steel, Teflon tubing, Teflon-lined Tygon tubing and Teflon filter holders were used to minimize ozone loss to the surfaces of the flow system.

Each sample was cut from the corresponding filter and placed in a Teflon holder (of 47 mm diameter), which fit tightly into a Teflon flow tube. The mass of the filter before and after exposure to ozone was recorded, although in most cases the mass change due to reaction with ozone was negligible.

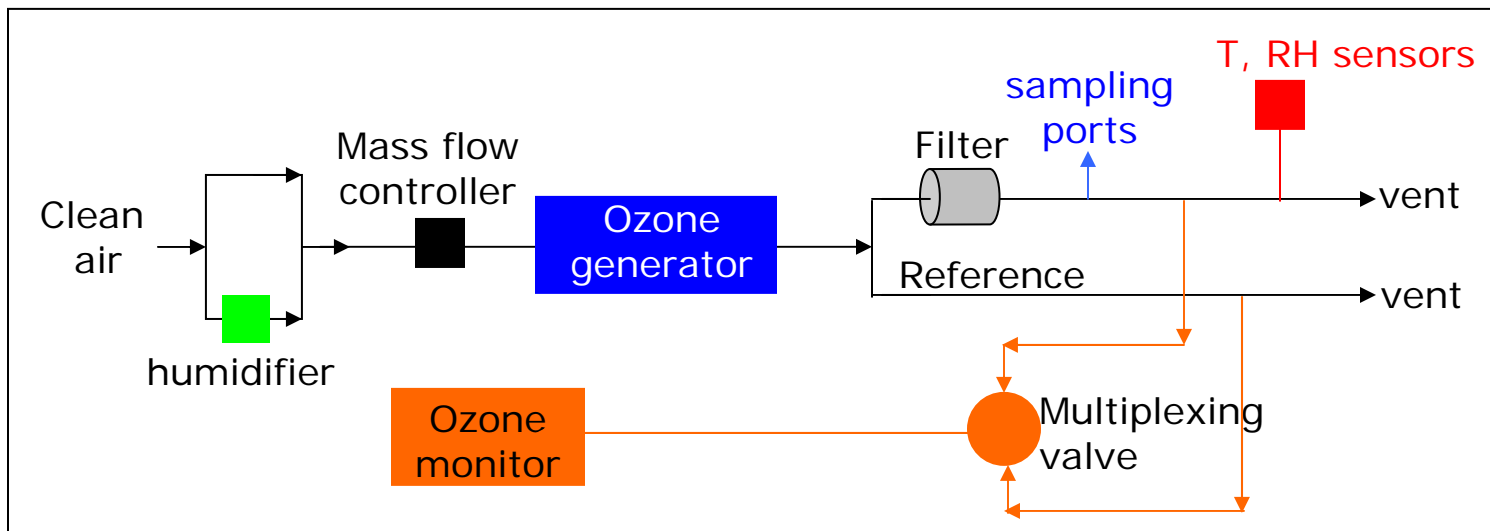

Figure 1: Flow tube experimental setup

### 2.3. Sample Collection

In samples placed downstream of the filters, volatile carbonyls (aldehydes and ketones) formed in the oxidation of filter media and dust particles deposited on the filters were collected. The samplers (Waters model # WAT047205) consisted of silica gel cartridges impregnated with DNPH (dinitro phenylhydrazine), a derivatization reactant specific to carbonyls. Derivatization reactions allow to stabilize labile analytes, allowing for their preservation and chromatographic analysis. DNPH-coated samplers were preceded by an ozone scrubber (Waters Corp., model # WAT054420) to remove ozone from the sampling stream. The flow through the sampler was measured immediately before starting and at the end of the sampling period (~10 h), and was used, together with the sampling time, to determine the volume of air that was collected. The exposed samplers were extracted with 2-mL acetonitrile (aprotic polar solvent) and analyzed by high performance liquid chromatography (HPLC) with ultraviolet (UV) detection (Agilent 1200 system). Formaldehyde and acetaldehyde were quantified with a calibration curve prepared with authentic standards of the DNPH hydrazone derivatives.

## 3.0 Results

### 3.1. Ozone Loss in HVAC Filters

Used and unused HVAC filters were exposed to air containing  $150 \pm 5$  ppbv of ozone at the inlet, representing typically high outdoor ozone conditions. In each case, two experiments were performed, with dry and humid air (at  $50 \pm 5$  %RH). Ozone breakthrough curves were recorded, similar to those shown in Figures 2 and 3 for each of the studied filters. In Figure 2, experimental data corresponding to an unused filter were recorded, and in Figure 3 results from the same filter material used in the Building H were recorded. At least one filter from each building was investigated. In both Figures, the filter media was a cotton/polyester blend. The data are presented as % ozone concentration change at the filter outlet ( $\% \Delta O_3$ ) as a function of time, with respect to inlet ozone concentrations. Figures 2 and 3 show the experimental data points together with a simple monoexponential fitting, that allowed determination of the time at which outlet ozone concentration reached steady state ( $t_{st.st.}$ ). The figures show the average ozone concentration change  $\Delta[O_3]$  with respect to inlet concentrations, corresponding to the initial period (i.e., for  $t < t_{st.st.}$ ) and for the steady state period (i.e., for  $t > t_{st.st.}$ ) in each case.

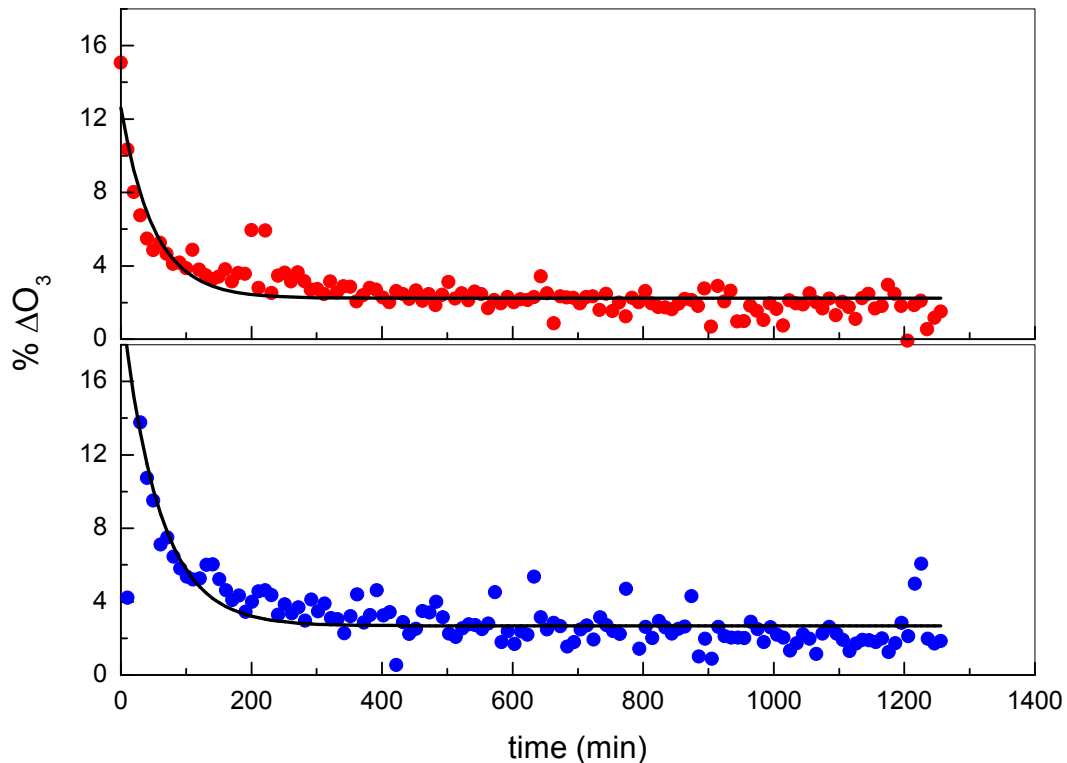

**Figure 2: Ozone breakthrough curves corresponding to unused cotton/polyester filters under humid (red) and dry (blue) air.**

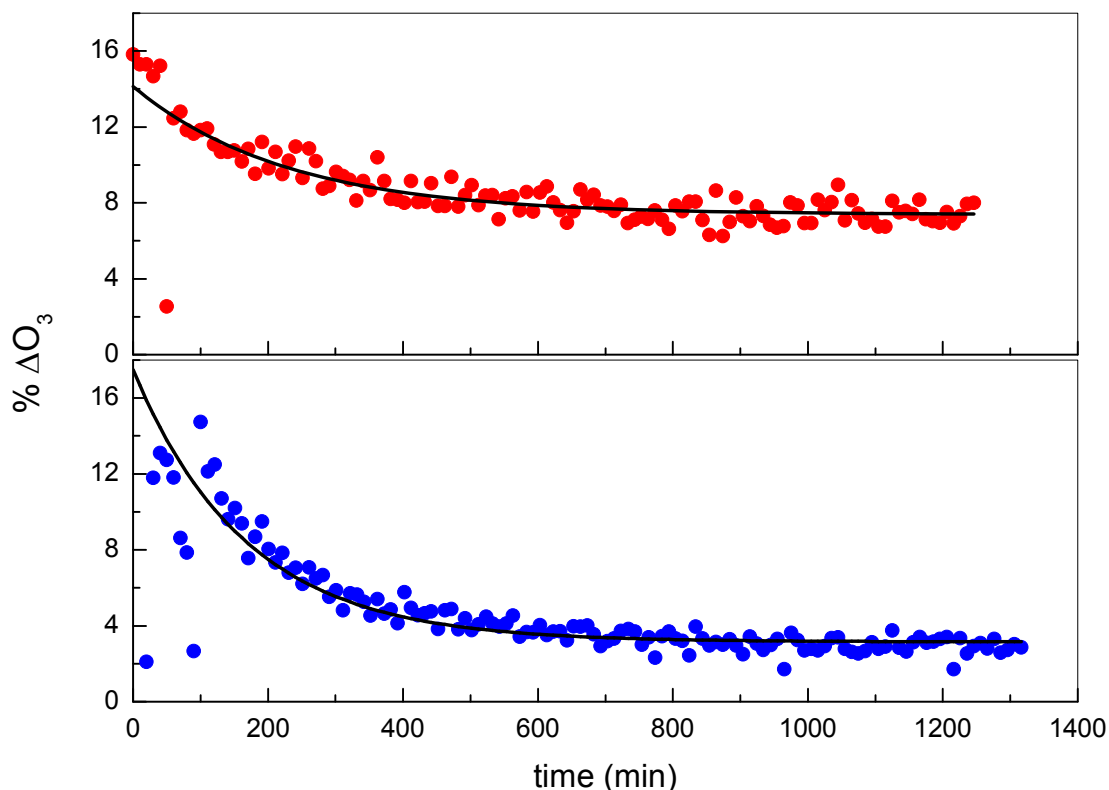

**Figure 3: Ozone breakthrough curves corresponding to cotton/polyester filters used in Building H (classrooms) tested in the laboratory under humid (red) and dry (blue) air conditions.**

The values of the experimental conditions corresponding to each experiment, as well as the  $t_{st.state}$  value and the average ozone concentration drop  $\Delta[O_3]$ , are reported in Table 1 (for the unused filters) and in Table 2 (for the used filters). Tables 1 and 2 also include the mass of ozone consumed during the initial period (in  $\mu\text{g } O_3$ ), and the rate of reaction (in  $\mu\text{g } O_3 \text{ h}^{-1}$ ) at steady state conditions.

The information presented in Figures 2 and 3 and Tables 1 and 2 serve as the basis for the evaluation of the ozone uptake capacity of HVAC filters used in classrooms and other school buildings. In all cases, an initial higher ozone loss rate was observed, which was subsequently reduced to a lower but, in most cases, non-zero value. The times required to reach steady state conditions with unused filters were in the range of 72-209 minutes. For used filters, longer times, up to 537 minutes, were observed.

In the case of unused filters, the ozone uptake capacity of fiberglass filters was compared with that of a cotton/polyester matrix. The latter showed higher reactivity with ozone both during the initial reaction period and, particularly, at steady state conditions, during which the reactivity of the fiberglass material was negligible.

**Table 1: Experimental conditions and results for unused filters**

Filter Material	Inlet [O <sub>3</sub> ]	RH	<i>t</i> <sub>st.state</sub>	Δ[O <sub>3</sub> ]		Mass of O <sub>3</sub> reacted	
				Initial	St.State	Initial	St.State
	(ppbv)	(%)	(min)	(ppbv)	(ppbv)	(μg O <sub>3</sub> )	(μg O <sub>3</sub> · h <sup>-1</sup> )
FG	145 ± 3	0	209	1.9	n.d.	2.80	n.d.
FG	144 ± 1	52 ± 5	72	4.6	n.d.	1.20	n.d.
C/P	141 ± 3	0	163	9.5	1.24	4.81	0.196
C/P	145 ± 1	54 ± 5	118	7.1	1.29	1.33	0.200

FG: fiberglass

C/P: cotton-polyester blend

n.d.: non detected

**Table 2: Experimental conditions and results for used filters**

Building	Filter Material	Inlet ozone	RH	<i>t</i> <sub>st.state</sub>	Δ[O <sub>3</sub> ]		Mass of O <sub>3</sub> reacted	
					Initial	St.State	Initial	St.State
	(ppbv)	(%)	(min)	(ppbv)	(ppbv)	(μg O <sub>3</sub> )	(μg O <sub>3</sub> · h <sup>-1</sup> )	
Gym	C/P	153 ± 14	0	228	7.9	1.0	4.68	0.159
Gym	C/P	157 ± 1	55 ± 5	192	8.5	1.9	4.22	0.303
Bldg D	C/P	195 ± 1	0	537	8.3	1.8	9.77	0.242
Bldg D	C/P	167 ± 1	58 ± 5	90	41.5	6.1	9.72	0.946
Bldg G	C/P	142 ± 2	0	241	9.9	1.6	6.15	0.243
Bldg G	C/P	196 ± 12	59 ± 5	121	29.2	7.6	8.75	1.120
Bldg H	C/P	139 ± 1	0	446	8.9	1.1	10.16	0.174
Bldg H	C/P	144 ± 1	69 ± 5	434	12.4	4.9	13.88	0.747

C/P: cotton-polyester blend

n.d.: non detected

Used filters included in this study comprised exclusively cotton/blend matrices. Except for the filter obtained from the Gym, all other filters (corresponding to classrooms and an administrative building) presented significantly higher ozone uptake than unused filters when exposed to humid air, but remained at the same ozone levels corresponding to unused filters in the presence of dry air. During the initial period under humid air, filters from buildings D, G and H reduced ozone concentrations in 12-41 ppbv, and at steady state conditions in the range 4.9 – 7.6 ppbv. This significant effect may be attributed to the presence of a different composition of material collected in those filters with respect to the Gym. Higher reactivity of

the filter from Bldg H under humid air was also correlated with higher acetaldehyde levels measured downstream (see next section).

### **3.2. Identification and Quantification of Oxidation Byproducts**

One DNPH sample was collected from each experimental condition, and additional experiments were performed to determine formaldehyde and acetaldehyde concentrations in the system operating with humid air, with and without ozone, in the absence of filters. The laboratory blank (i.e., the concentrations determined in extraction of new DNPH cartridges that were not exposed to air from the experiments) was determined by extracting five DNPH cartridges. The average concentration of formaldehyde of the blank samples was determined to be  $0.02 \pm 0.05 \mu\text{g}/\text{m}^3$ ; the acetaldehyde blank concentration was  $0.04 \pm 0.05 \mu\text{g}/\text{m}^3$ . In both cases, the experimental uncertainty was one standard deviation.

Results obtained for experiments with unused cotton/polyester filter media, and with the same filter used in Bldg H and in the Gym are presented in Figure 4 for formaldehyde, and in Figure 5 for acetaldehyde. Overall, concentrations were low, and in several samples close to the limit of detection. Maximum levels of formaldehyde were found for humid air, even in the absence of ozone, suggesting the presence of a source that emits formaldehyde through hydrolysis. Possible sources of formaldehyde in the presence of moisture are polymers used as binders to keep the fibers together, impaction oils used to improve particle adhesion to the fibers, or other additives that may be present in the filter surface. However, the presence of ozone led to higher formaldehyde and acetaldehyde concentrations downstream of the filter under humid air, indicating the presence of heterogeneous chemistry that yields both aldehydes. Little difference was observed between formaldehyde levels downstream of filters from Bldg H and the Gym, but acetaldehyde was significantly higher in Bldg H samples, consistent with the higher ozone uptake recorded for that sample.

The formation of ultrafine secondary aerosol particles was explored using a P-TRAK analyzer, which is an optical particle counter sensitive in the aerosol particle range 20 – 1000 nm, but no significant particle concentrations were observed in our experimental conditions.

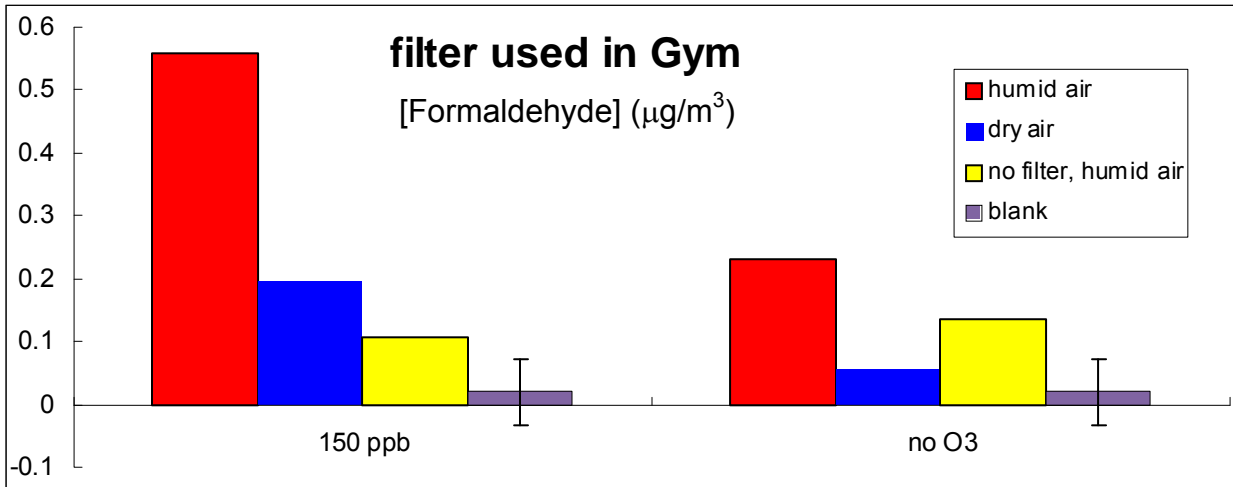
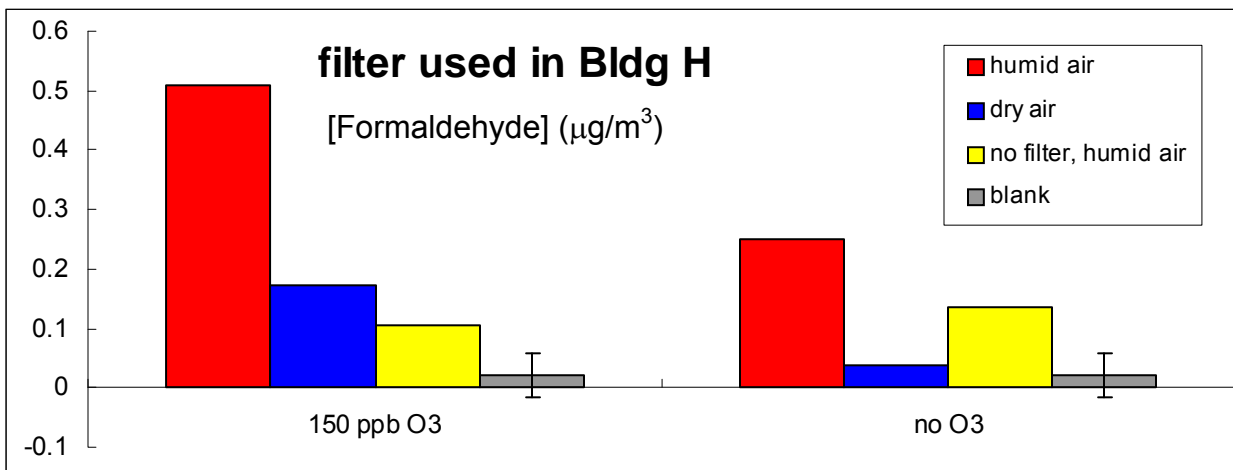
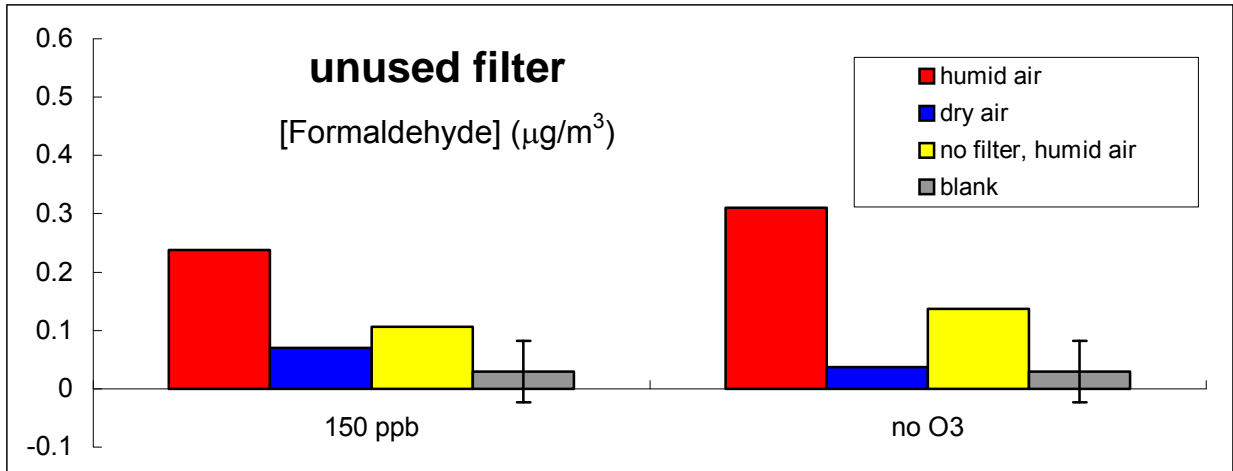

**Figure 4: Average outlet formaldehyde concentrations for unused cotton/polyester blend media, and for the same filter material used in Bldg H and in the Gym building. The error bar indicates one standard deviation of five blank determinations. Chronic Reference Exposure Level (CREL) for formaldehyde is  $3 \mu\text{g m}^{-3}$ .**

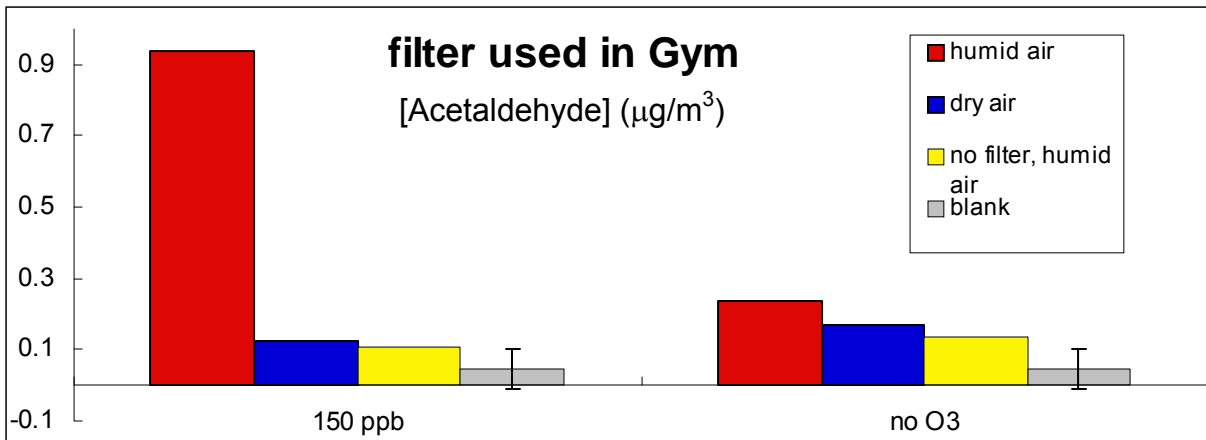
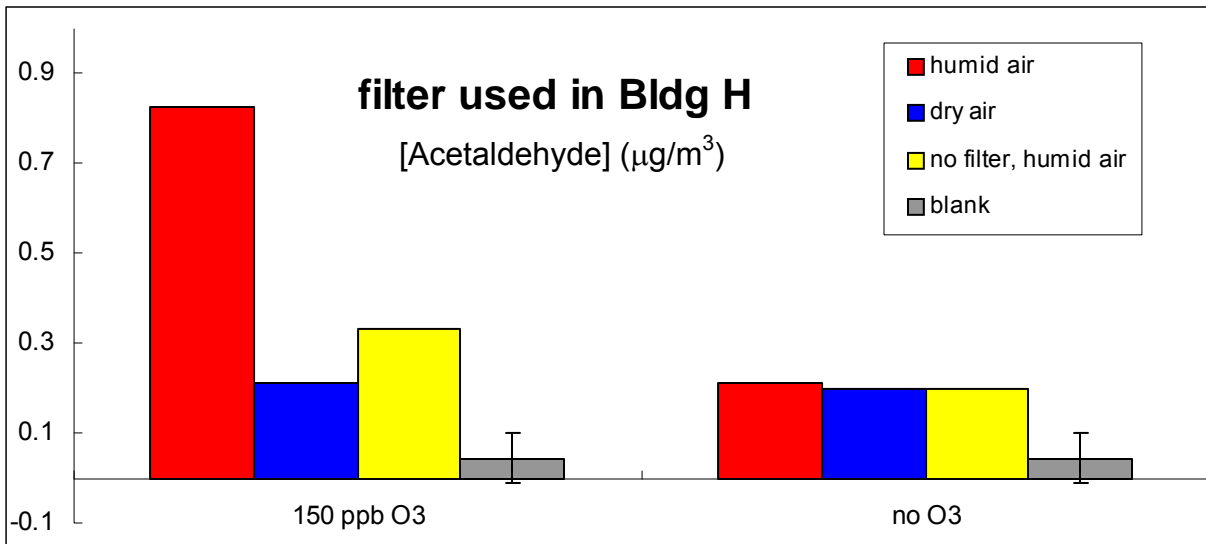
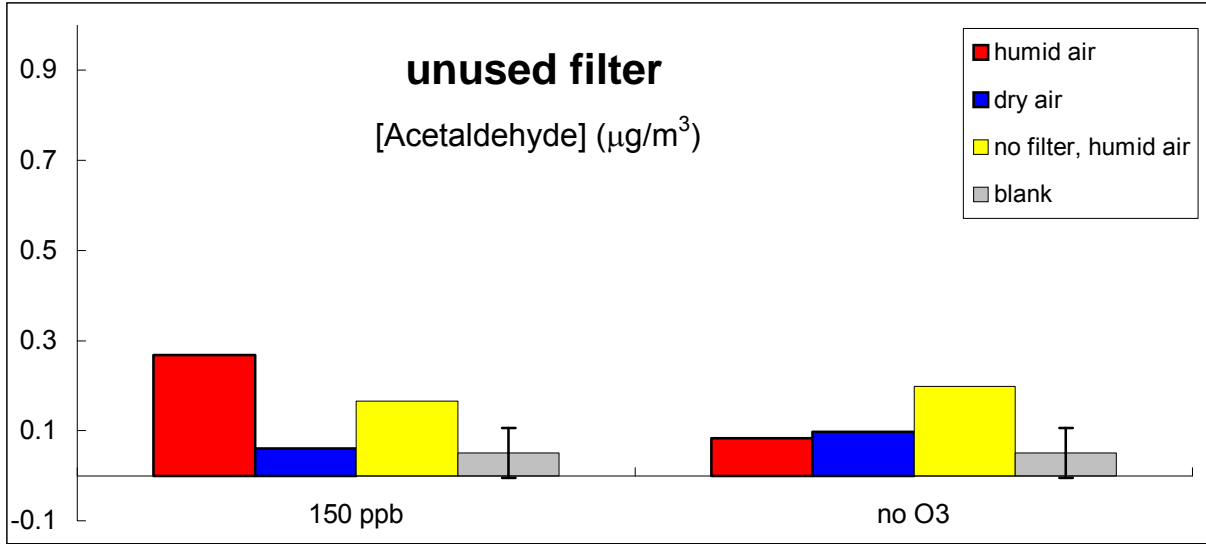

Figure 5: Average outlet acetaldehyde concentrations for unused cotton/polyester blend media, and for the same filter material used in Bldg H and in the Gym building. The error bar indicates one standard deviation of five blank determinations. Chronic Reference Exposure Level (CREL) for acetaldehyde is  $9 \mu\text{g m}^{-3}$ .

### 3.3. Estimated Impact in School Air Quality

The information presented in Sections 3.1 and 3.2 allows for a first-order estimation of the impact of these reactions on the air quality of schools.

In terms of ozone uptake and filter reactivity, the filters used in classrooms and administrative buildings (i.e., buildings with high occupancy) had higher ozone reactivity than the filters used in the gymnasium, possibly related with a higher effect of indoor particle sources in the classrooms and administrative buildings, assuming that outdoor particle sources are essentially the same for all buildings. This assumption is reasonable given the absence of strong sources (such as vegetation) in the proximity of the rooftop HVAC intakes. The observed reductions in inlet ozone concentration in buildings D, G and H, corresponding to 12-41 ppbv for the initial period of exposure, and of 4.9 – 7.6 ppbv at steady state operation, suggest that ventilation filters can be a significant ozone sink in the indoor environment. Considering that the incoming ozone concentration in the experiments was ~150 ppbv, those values correspond to 8 – 27 % and 3 – 5 % of inlet ozone, respectively. Weschler (2000) reviewed indoor/outdoor (I/O) ozone ratios reported by various researchers in different cities and building types, and observed that, in most cases, I/O values were in the range 0.3 – 0.7. Among the reviewed buildings, several results corresponding to schools are listed in Table 3.

**Table 3: Indoor/outdoor (I/O) ratios reported for school buildings and their estimated ozone loss for high outdoor ozone conditions**

Building	Location	I/O ratio	$\Delta O_3^*$ (ppbv)
2 schools	So. California	0.3 – 0.7	45 – 105
1 school	Chicago	0.5 – 0.7	45 - 75
Gymnasium	Munich	0.5 – 1.0	0 - 75
3 Schools	Mexico City	0.3 – 0.4	90 – 105

\* estimated for a benchmark outdoor  $O_3$  concentration of 150 ppb

Source: Adapted from Weschler (2000).

These scenarios indicate that the extent of ozone loss observed in HVAC filters is likely to be a significant contributor of total ozone loss in schools. For example, for a I/O ratio of 0.7, the steady-state ozone loss of 4.9 – 7.6 ppbv measured in this study is equivalent to 11 – 17 % of the total ozone loss.

It is important to keep in mind that, in the experimental conditions of this study, steady state conditions are reached only after a period of several hours of continuous exposure to high levels of ozone. However, the outdoor ozone concentration profile is not constant; it increases during the morning and early afternoon, and decreases in the evening and night (Weschler, 2000). This daily cycle allows for regeneration of reactive species in the filter and in dust particles deposited on the filter, leading to an increase of ozone removal efficiency on the following day (Zhao et al., 2007; Bekö et al., 2003). For that reason, using the steady-state conditions from this study to evaluate the contribution of HVAC filters to total building ozone deposition can be considered a conservative approach.

Molar yields of formaldehyde ( $Y_F$ ) and acetaldehyde ( $Y_A$ ) were estimated as the ratios:

$$Y_F = \frac{[Formaldehyde]}{\Delta[O_3]} \times 100 \quad (1)$$

and

$$Y_A = \frac{[Acetaldehyde]}{\Delta[O_3]} \times 100 \quad (2)$$

where the  $[Formaldehyde]$ ,  $[Acetaldehyde]$  and  $[O_3]$  are in parts per billion (ppbv) units.

The calculated  $Y_F$  and  $Y_A$  values for unused and used cotton/polyester blend filters are listed in Table 4.

**Table 4: Estimation of yields of formaldehyde( $Y_F$ ) and acetaldehyde ( $Y_A$ ) corresponding to a cotton/polyester blend filter.**

Filter	$Y_F$		$Y_A$	
	Dry air	Humid air	Dry air	Humid air
Unused	2.46	9.45	2.31	12.0
Used – Bldg H	3.04	4.69	2.10	4.32
Used – Gym	6.97	15.4	3.03	17.6

For both aldehydes and every filter, yields under humid air were higher than yields under dry air, further supporting the observations of higher reactivity in the presence of moisture. The unused filter presented relatively high yields because the ozone concentration change ( $\Delta[O_3]$ , in the denominator) was relatively small as compared with used filters.

The change in indoor aldehyde concentration,  $\Delta C_{aldehyde}$ , from the aldehyde production rates at the filters can be estimated from the following equation which is based on a mass balance:

$$\Delta C_{aldehyde} = \frac{Q_F (Y_{aldehyde} / 100) \Delta C_{ozone}}{Q_{OA}} \quad (3)$$

where  $Q_F$  is the rate of air flow through the filters used to serve the space,  $Y_{aldehyde}$  is the yield,  $\Delta C_{ozone}$  is the concentration loss of ozone in the filter, and  $Q_{OA}$  is the rate of outdoor air supply to the space. Based on data presented from a large survey in California classrooms (<http://www.arb.ca.gov/research/indoor/pes/pes-fr/pes-fr.htm>), a typical value for the ratio of  $Q_F$  to  $Q_{OA}$  is 1.58

The results listed in Table 4 suggest that byproducts formed in ozone deposition on the filter media and the dust and particles deposited on its surface may be small contributors to indoor formaldehyde and acetaldehyde levels. The expected formaldehyde concentration change resulting from an ozone loss at the filter of  $\Delta C_{ozone} = 10$  ppbv is in the range 0.32 – 2.4 ppbv. For acetaldehyde, a similar ozone deposition would lead to an increase in concentration of 0.32 – 2.7 ppbv. This estimation assume that byproducts yields measured in this study at a velocity of 0.0125 m.s<sup>-1</sup>

through the filter are representative of the byproduct yields expected in actual filter deployments where the velocity of airflow through filter media is typically about  $0.5 \text{ m s}^{-1}$ . Because the effects of higher air velocities or inlet ozone concentration on the yields of aldehydes reported above were not investigated, readers should be advised that the estimates of the concentration increases of indoor aldehydes have a large uncertainty in this study.

The small production rates of formaldehyde and acetaldehyde and negligible production of particles in this study are encouraging, but these findings are not a basis for concluding that ozone reactions on filters do not result in important increases in indoor pollutant concentrations. Other types of pollutants may have been released when ozone reacted on the filters. The integrated aldehyde measurements may not adequately screen for reactive species that are less stable than formaldehyde and acetaldehyde and possibly irritating at lower concentrations. Future work on real time measurements using a proton transfer – mass spectrometry (PTR-MS) approach might shed more light on species that are not observable with the methods used in the current study.



## 4.0 Conclusions

This exploratory result provided quantitative information on ozone loss and byproduct formation of filters used in school buildings, as well as of unused filters of the same type. The main observations are:

- Ozone losses in filters taken from classrooms are significant in magnitude to partially explain prior findings that indoor ozone concentrations are often 30% to 70% lower than outdoor ozone concentrations.
- The reactions of ozone on particle loaded filters from classrooms are a source of formaldehyde and acetaldehyde. The expected increases in indoor air concentrations of formaldehyde and acetaldehyde from this source are small relative to typical concentrations of these compounds in classrooms but significant relative to the California EPA chronic reference exposure level of 2.5 ppbv for formaldehyde.
- More research is needed before conclusions can be drawn about the health significance of ozone's reactions with the filters used in classrooms. Conclusions presented here are based on a limited set of experiments, which provide initial indications and guidance for future research. For example, more information is required on the relative impact of ozone reactions with filters with respect to other existing formaldehyde sources. In the absence of other strong sources, more information is needed on long-term low-level exposure to volatile aldehydes. Similar tests should be performed with filters of different types, locations and with a broader spectrum of analysis for production of other types of pollutants.



## 5.0 References

- Apte Michael G.; Buchanan ISH; Mendell Mark J. (2008). "Outdoor Szone and Building-Related Symptoms in the BASE Study." *Indoor Air* 18, 156-170.
- Bekö G; Halás O; Clausen G; Weschler CJ; Toftum J (2003) "Initial Studies of Oxidation Processes on Filter Surfaces and their Impact on Perceived Air Quality." *Proceedings of Healthy Buildings 2003*, 3, 156-162.
- Bekö G; Tamas G; Halás O; Clausen G; Weschler CJ (2005) "Ultra-Fine Particles as Indicators of the Generation of Oxidized Products on the Surface of Used Air Filters." *Proceedings of the 10<sup>th</sup> International Conference on Indoor Air Quality and Climate (Indoor Air 2005)*, X Yang, B Zhao, R Zhao, Eds., Tsinghua University Press, Beijing, China, 1521-1525.
- Buchanan ISH; Mendell Mark J; Mirer AG; Apte Michael G (2008). "Air Filter Materials, Outdoor Ozone and Building-Related Symptoms in the BASE Study." *Indoor Air* 18, 144-155.
- Clausen G; Alm O; Fanger PO (2002). The Impact of Air Pollution from Used Ventilation Filters on Human Comfort and Health." In *Indoor Air 2002: Proceedings of the 9<sup>th</sup> International Conference on Indoor Air Quality and Climate*. H. Levin Edit. 1, 338-343.
- Clausen G (2004). "Ventilation Filters and Indoor Air Quality: a Review of Research from the International Centre for Indoor Environment and Energy." *Indoor Air* 14, 202-207.
- Cogliano VJ; Grosse Y; Baan RA; Straif K; Secretan MB; El Ghissassi F. "Meeting Report: Summary of IARC Monographs on Formaldehyde, 2-butoxyethanol and 1-tert-butoxy-2-propanol." *Environ. Health Perspectives*, 113, 1205-1208.
- Destailats Hugo; Lunden MM; Singer BC; Coleman BK; Hodgson AT; Weschler CJ; Nazaroff WW. (2006) Indoor Secondary Pollutants from the Use of Household Products in the Presence of Ozone." *Environ. Sci. Technol.*, 40, 4421-4428.
- Fadeyi MO; Tham KW; Zuraimi MS (2006). "Effects of Filtration on Secondary Organic Aerosols Generated by Indoor Ozone-limonene Reactions." *Proceedings of the Healthy Buildings 2006 Conference*, Lisboa, Portugal. E. de Oliveira Fernandes, M. Gameiro da Silva, J. Rosado Pinto, Eds. Univ. de Porto, Vol. IV, 445-448.
- Girman JR; Womble SE; Ronca EL. (1995) "Developing Baseline Information on Buildings and Indoor Air Quality (BASE 94): Part II – Environmental Pollutant Measurements and Occupant Perceptions." *Proceedings of Healthy Buildings 95*, Vol. 3, 1311-1316.
- Hodgson AT, Shendell DG, Fisk WJ, Apte Michael G. "Comparison of Predicted and Derived Measures of Volatile Organic Compounds Inside Four New Relocatable Classrooms." *Indoor Air*, 14, 135-144.

- Hodgson AT; Levin H (2003). "Volatile Organic Compounds in Indoor Air: a Review of Concentrations Measured in North America Since 1990." *Lawrence Berkeley National Laboratory Report LBNL-51715*. <http://eetd.lbl.gov/ie/pdf/LBNL-51715.pdf>
- Hyttinen, M; Pasanen, P; Salo, J; Bjorkroth, M; Vartiainen, M; Kalliokoski, P. (2003). "Reactions of Ozone on Ventilation Filters." *Indoor Built Environ* 12, 151-158.
- Hyttinen, M; Pasanen, P; Kalliokoski, P. (2005). "Reactions of Ozone on Supply Air Filters." *Proceedings of the 10<sup>th</sup> International Conference on Indoor Air Quality and Climate (Indoor Air 2005)*, X Yang, B Zhao, R Zhao, Eds., Tsinghua University Press, Beijing, China, 2381-2385.
- Hyttinen M; Pasanen P; Kalliokoski P (2006). "Removal of Ozone on Clean, Dusty and Sooty Supply Air Filters." *Atmos. Environ.* 40, 315-325
- Mendell MJ, Heath GA. "Do Indoor Pollutants and Thermal Conditions in Schools Influence Student Performance? A Critical Review of the Literature." *Indoor Air*, 15, 27-52.
- Mysen M, Fostervold KI, Schild PG. "An Intervention Study of the Impact of Supply Air Filters on Perceived Air Quality and Health Symptoms in a Primary School." *Proceedings of Healthy Buildings 2006 Conference*. Lisbon, Portugal, June 2006. Edits. Oliveira Fernandes E, Gameiro da Silva M, Rosado Pinto J. Univ. de Porto, Vol III, 213-216.
- Pasanen PO; Teijonsalo J; Seppanen O; Ruuskanen J; Kalliokoski P. (1994). "Increase in Perceived Odor Emissions with Loading of Ventilation Filters." *Indoor Air* 4, 106-113.
- US EPA (2003). A Standardized EPA Protocol for Characterizing Indoor Air Quality in Large Office Buildings." *Indoor Environment Division USEPA*, Washington DC. [http://www.epa.gov/iaq/largebldgs/base/images/2003\\_base\\_protocol.pdf](http://www.epa.gov/iaq/largebldgs/base/images/2003_base_protocol.pdf)
- Weschler, CJ. (2000). "Ozone in Indoor Environments: Concentration and Chemistry." *Indoor Air* 10, 269-288.
- Weschler, CJ. (2004). "Chemical Reactions Among Indoor Pollutants: What We've Learned in the New Millennium." *Indoor Air* 14, 184-194.
- Zhao, P., Siegel, J.A., Corsi, R.L. (2007) "Ozone Removal by HVAC Filters." *Atmos. Environ.* 15, 3151-3160.

## List of Acronyms

Energy Commission: California Energy Commission

CREL: Chronic reference exposure level

DNPH: Dinitrophenyl hydrazine

GC/MS: Gas chromatography/Mass spectrometry

HPLC: High performance liquid chromatography

HVAC: Heating, ventilation and air conditioning

IAQ: Indoor air quality

LBNL: Lawrence Berkeley National Laboratory

NIOSH: National Institute for Occupational Safety and Health

ppbv: Volumetric Parts Per Billion

RH: Relative humidity

SBS: Sick building syndrome

SVOC: Semi-volatile organic compound

TD: Thermal desorption

VOC: Volatile organic compound