

# ASME AG-1 Absolute®

ASME AG-1 Size 7 & Size 4 HEPA Filters

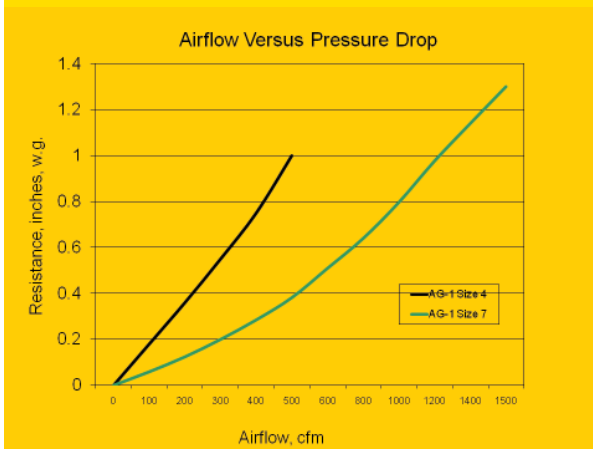

Absolute filter integrity  
in compliance with  
ASME AG-1



The Camfil Farr AG-1 Absolute protects critical environments by ensuring that the system airflow design specifications are maintained.

Camfil Farr nuclear-qualified AG-1 Absolute filters are ASME<sup>1</sup> AG-1 and UL<sup>2</sup> 586 listed. They are manufactured from the highest quality components as prescribed in Section FC, Article 3000 of ASME AG-1, under a DOE<sup>3</sup> audited and approved NQA-1 Quality Program. They are provided with a Certificate of Conformance as specified in Article FC-8000 of ASME AG-1.

Each nuclear grade AG-1 Absolute filter has a tested efficiency of not less than 99.97% on 0.3 micron size particles at 100% of rated airflow and at 20% of rated airflow.

Every Camfil Farr nuclear grade AG-1 Absolute filter:

- Includes 303 square feet of media area in a Size 7 filter, and 108 square feet of media area in a Size 4 filter. The media is qualified ASME AG-1, Appendix FC-I. It is highly resistant to moisture, and capable of operation to 99% relative humidity.
- Uses a fire-retardant phosphorus-free polyurethane adhesive sealant, bonding the frame to the media pack.
- Has a 14-gauge ASTM-A-240 Type 304 stainless steel enclosing frame.
- Includes 4 x 4 wire mesh fabric face guards on the air-entering and air-exiting sides of each media pack.
- Size 7 is available in a gasket seal Size 4 is available in gasket seal and gel seal versions, in accordance with ASME AG-1, FC-3122 to ensure a leak-free filter-to-housing or filter-to-frame seal.
- Gel seal models include filter extraction clips to accommodate the change of filters.
- May be operated at continuous temperature of up to 250° F (121° C).
- Is labeled as specified in ASME AG-1, FC-9000 and in DOE STD-3020-2005, 6.1.4.

The Camfil Farr AG-1 Absolute's integrity ensures continued protection of hazardous environments, and when changed in accordance with recognized procedures, protects the health of filter service personnel.

<sup>1</sup> ASME - American Society of Mechanical Engineers

<sup>2</sup> UL - Underwriters Laboratories

<sup>3</sup> Department of Energy



Camfil Farr	Product sheet
AG-1 Absolute Filter	1801AG - 0909
Camfil Farr - clean air solutions	

**PERFORMANCE DATA**

**ASME AG-1 ABSOLUTE®**

Part Number	Airflow Capacity (cfm)	Resistance @ Capacity (inches, w.g.)	ASME AG-1 Size	Filter Height (H) (inches)	Filter Width (W) (inches)	Filter Depth (D) (inches)	Seal
855211138 Contact Factory	1500	1.3	7	24	24	11-½	Gel Seal
855211139	1500	1.35	7	24	24	11-½	Gasket Seal
855211140	500	1.00	4	24	24	5-7/8	Gasket Seal
855211141	500	1.00	4	24	24	5-7/8	Gel Seal

**DATA NOTES**  
 Gasket seal dimensionals shown to the right, gel seal version not shown.  
 Efficiency is 99.97% on particles 0.3 micron in size.  
 Rated airflow in ACFM based on tests indoors at atmospheric pressure.  
 Maximum continuous operating temperature 250° F (121° C).  
 Final operating resistance should not exceed 4.0" w.g.  
 ASME AG-1 Absolute filters meet all applicable requirements as published under in the following documents; ASME AG-1, ASME NQA-1, ASME N509-1989, UL 586.  
 Camfil Farr nuclear grade HEPA filters have been qualified by the Edgewood Chemical Biological Center to meet the performance requirements of ASME AG-1 Sections FC-4000 & FC-5000, with the exceptions of FC-5150 Resistance to Heated Air and FC-5160 Spot Flame Resistance which have been qualified by the UL 586 listing of the product.  
 For complete construction components please consult sales submittal drawings 502852, 502880 or 502881 respectively.

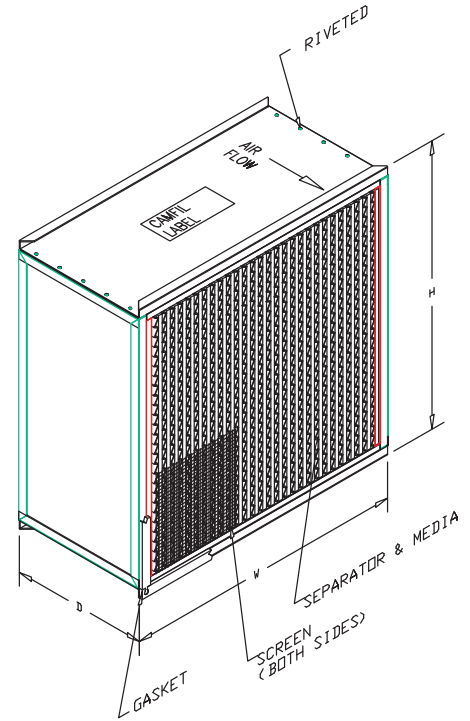

**SPECIFICATIONS**

**Air Filters—1.0 General**

**1.1** - Air filters shall be Camfil Farr Model \_\_\_\_\_ ASME AG-1 qualified and UL 586 listed HEPA air filters with mini pleated ASME AG-1, Appendix FC-I qualified HEPA media in the ASME AG-1, FC-1121 Type A pleat configuration, polyurethane media-to-frame sealant, Type 304 stainless steel enclosing frame, 18 gauge 4x4 wire mesh media pack face guards and a filter face gasket to ensure filter seal integrity.

**1.2** - Overall dimensions shall be 24" high by 24" wide by 11-½" deep.

**2.0 Construction**

**2.1** - The media shall be manufactured from waterproof borosilicate glass micro fibers and a synthetic binder formed into a continuous flat sheet with physical and functional properties. The test results shall be traceable to manufacturing lot number, roll number and the serial number of the final product. The media shall be qualified in accordance with ASME AG-1, Appendix FC-I.

**2.2** - The media shall be formed into individual mini pleats 27.5 mm height, separated by glass thread fibers that are bonded to the media at spacing of 22 mm on both sides of the media pack, and assembled into a V-bank configuration. The packs shall be potted into the enclosing frame with a heat-resistant silicone sealant<sup>1</sup>.

**2.3** - The enclosing frame shall be of 14-gauge Type 304 stainless steel and bonded to the media pack to form a rugged and durable enclosure. Overall dimensional tolerance shall be +0/ - 1/8" on the face dimensions, +1/16" / - 0 on the depth dimension. The face shall be square within a tolerance of 1/8" when measured diagonally across the corners of both faces.

**2.4** - The assembled filter shall include media pack face guards constructed of ½ - 20 expanded and flattened 20-gauge Type 304

stainless steel. Screens shall be on the air-entering and air-exiting sides of each media pack. The face screens shall have a minimum open area of 74%.

**2.5** - The filter shall include a continuous gel channel filled with silicone gel sealant<sup>1</sup> in accordance with ASME AG-1, FC-3122 to effect a filter-to-housing or filter-to-frame seal.

**2.6** - Four filter extraction clips shall be provided, if specified for filters installed in a bag-in/bag-out containment housing.

**3.0 Performance**

**3.1** - The filter shall be qualified to meet the performance requirements of ASME AG-1, Sections FC, Article 4000 and FC, Article 5000.

**3.2** - The filter shall be listed by Underwriters Laboratories as UL 586 and labeled accordingly.

**3.3** - The filter shall be capable of operating at 400° F (204° C) continuous.

**3.4** - Manufacturer shall supply a Certificate of Conformance with each filter detailing manufacturers name, model number, unique filter serial number, resistance to airflow at rated capacity, percent penetration on particles 0.3 micron in size at 100% of rated airflow and at 20% of rated airflow. The filter shall be labeled as specified in ASME AG-1, FC-9000 and in DOE STD-3020-2005, 6.1.4.

**3.5** - ASME AG-1 HEPA filter shall be manufactured in a facility with a DOE audited and approved NQA-1 Quality Program.

<sup>1</sup> Gelatinous seal of Polydimethylsiloxane.

Camfil Farr has a policy of uninterrupted research, development and product improvement. We reserve the right to change designs and specifications without notice.

Camfil Farr  
 United States Tel: (973) 616-7300 Fax: (973) 616-7771  
 E-mail: camfilfarr@camfilfarr.com

